



# Tree Trimmer

## *Operator's Manual*

**MODELS:**                    **SRS-2400    TYPE 1**  
                                      **SRS-2100**  
                                      **Serial Number 001001 & Up**

**WARNING**  **DANGER**



The muffler or catalytic muffler and surrounding cover may become extremely hot.

Always keep clear of exhaust and muffler area, otherwise serious personal injury may occur.



**WARNING**



The engine exhaust from this product contains chemicals known to the State of California to cause cancer, birth defects or other reproductive harm.



**WARNING**  **DANGER**

Read rules for safe operation and instructions carefully. ECHO provides an Operator's Manual, which must be read and understood for proper and safe operation. Failure to do so could result in serious injury.

# INTRODUCTION

This ECHO product is a lightweight, high performance gasoline powered unit designed for tree trimming light to medium growth (4-1/2" Dia. Max.).

The Operators Manual provides information necessary for assembly, operation and maintenance.

If you require a replacement or additional manual, please write:

ECHO, INCORPORATED  
400 Oakwood Road  
Lake Zurich, IL 60047  
ATTN: Technical Publications

## WARNING ▲ DANGER

Follow rules for safe operation and operating instructions carefully. ECHO provides an operators manual that contains these items and it must be read for proper and safe operation.

# CONTENTS

Page No.

Decals .....	1
Description .....	2
Operation .....	3
Fuel .....	6
Starting and Stopping .....	7
Service and Maintenance Guide .....	8
Troubleshooting .....	8
Service .....	9
Assembly .....	14
Storage .....	15
Specifications .....	15

Specifications, descriptions and illustrative materials in this literature were accurate at the time of publication, but are subject to change without notice. Illustrations are representative and may include optional equipment and accessories and may not include all standard equipment.

## WARNING ▲ DANGER

- This unit can be dangerous and cause serious injury or death if improperly used. Operators, helpers and bystanders can be severely injured by falling objects and contact with the cutting attachment. To reduce the risk of injury to operator, helpers and bystanders; **READ AND UNDERSTAND THE OPERATORS MANUAL — WEAR EYE PROTECTION meeting ANSI Specification Z87.1, HEAD PROTECTION meeting ANSI Specifications Z89.1 and HEARING PROTECTION.**
- This unit is equipped with anti-vibration features. These features do not guarantee prevention of Raynaud's Syndrome (white finger disease). Read the operators manual for specific instructions regarding this subject.
- Use only ECHO approved accessories.
- Keep bystanders and helpers at least 33 feet (10 meters) away.

## WARNING ▲ DANGER

This unit is not designed to insulate against hazards associated with the contact of wires carrying electrical current.

To avoid possible injury/death due to electrical shock or other hazards, **DO NOT** operate unit if any wires (power, telephone, cable, etc.) are closer than 10 feet (3 meters) minimum distance, to any part of the unit or operator.

# DESCRIPTION

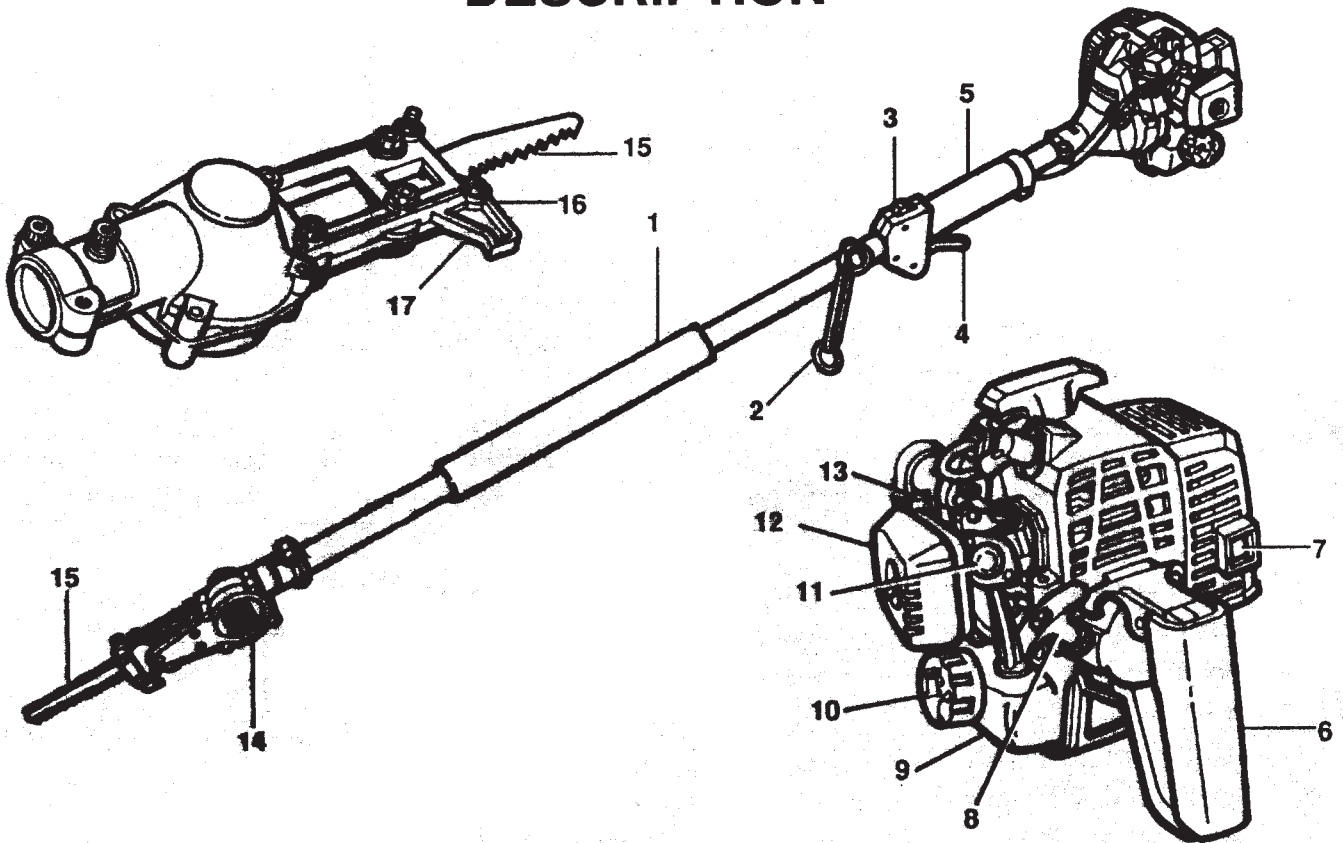

1. **Grip, Left Hand, Front** - This is a cushioned grip used when right hand is on center grip. See operation section for correct holding positions.
2. **Strap Hook** - Used to secure unit to shoulder strap.
3. **Ignition Switch** - "Slide Switch" mounted on top of Throttle Trigger Housing. Move switch forward to Run, Back to Stop.
4. **Throttle Trigger** - Spring loaded to return to idle when released. When accelerating, press trigger gradually for best operating technique. DO NOT hold trigger when starting.
5. **Grip, Center** - This is a cushioned grip for the right hand during Normal Reach Trimming or left hand when operating the Extended Reach Mode. See Operation Section for correct holding position.
6. **Handle, Rear, Right Hand** - This is a cushioned handle for Right Hand use during Extended Reach Mode. See Operation Section for correct holding positions.
7. **Muffler, Spark Arrester** - The spark arrester screen must be serviced monthly.
8. **Starter Handle** - Pull handle slowly until starter engages, then pull quickly and firmly. When engine starts, return handle slowly. DO NOT let handle snap back or damage to unit will occur.
9. **Fuel Tank** - Contains fuel filter and vent.
10. **Fuel Tank Cap** - Covers and seals fuel tank.
11. **Purge Bulb** - Pumping purge bulb before starting draws fresh fuel from tank to carburetor replacing air and old fuel. Pump bulb repeatedly (normally 3 to 4 times) until fuel is visible in "Clear" Fuel return line.
12. **Air Cleaner** - Contains replaceable heavy duty felt element.
13. **Choke Lever** - Controls operation of choke. Push lever in direction of arrow to CLOSE (starting position) choke. Pull back to OPEN (run position).
14. **Gear Box** -
15. **Blade** -
16. **Front Cutting Guide** - When pressed against branch being cut, steadies unit.
17. **Hook** - Can be used to pull cut branches from tree.

# OPERATION

## OPERATOR SAFETY

- Read this Tree Trimmer Operator's Manual carefully. Be sure you understand how to operate this unit properly before you use it.
- Wear non-skid sole shoes. Do not wear open-toed shoes or operate unit while bare footed.
- Wear proper clothing to protect your body.
- Wear eye, head and hearing protection devises.
- Use caution when handling fuel. Put the gas caps back tightly on both the gas can and the Tree Trimmer fuel tank. Move at least 10 feet from the re-fueling point and be sure there is no leakage of fuel from the gas cap or the fuel system before starting the engine.
- Operate this gasoline engine powered equipment in a well-ventilated area only.
- Start the unit on the ground with the throttle set at idle. **Do not** start if the blade is obstructed by the ground or any other object.
- Do not overreach or stand on unstable surfaces.
- Do not operate Tree Trimmer if ANY wires (power, telephone, cable, etc.) are closer than 10 feet (3 meters) minimum distance to any part of the unit or operator.
- Inspect area that Tree Trimmer will be used in. Remove metal objects and any other object that could jam or damage the Tree Trimmer.

## WARNING ▲ DANGER

Always stop the engine when a cutting head jam occurs. **DO NOT** attempt to remove an object causing a jam if the engine is running. Physical injury can occur if a jam is removed and the cutting head suddenly starts.

- Do not allow other persons or pets in the area when starting or using the Tree Trimmer.
- Keep a firm grip on the Tree Trimmer with both hands, the right hand on the center or rear handle, the left hand on the front handle. Use a firm grip with thumbs and fingers encircling the handles. A firm grip will help you keep control of the tree trimmer. **NEVER OPERATE** the trimmer with only one hand.
- Do all cutting at full throttle speed. Cutting at less than full speed can damage the clutch by allowing it to slip.
- Always carry the Tree Trimmer with the engine stopped and the **HOT** muffler away from your body.

## PREPARING FOR USE

### WARNING ▲ DANGER

Tree Trimmer users risk injury to themselves and others if the Tree Trimmer is used improperly, and/or safety precautions are not followed. Proper clothing and safety gear must be worn when operating a Tree Trimmer.

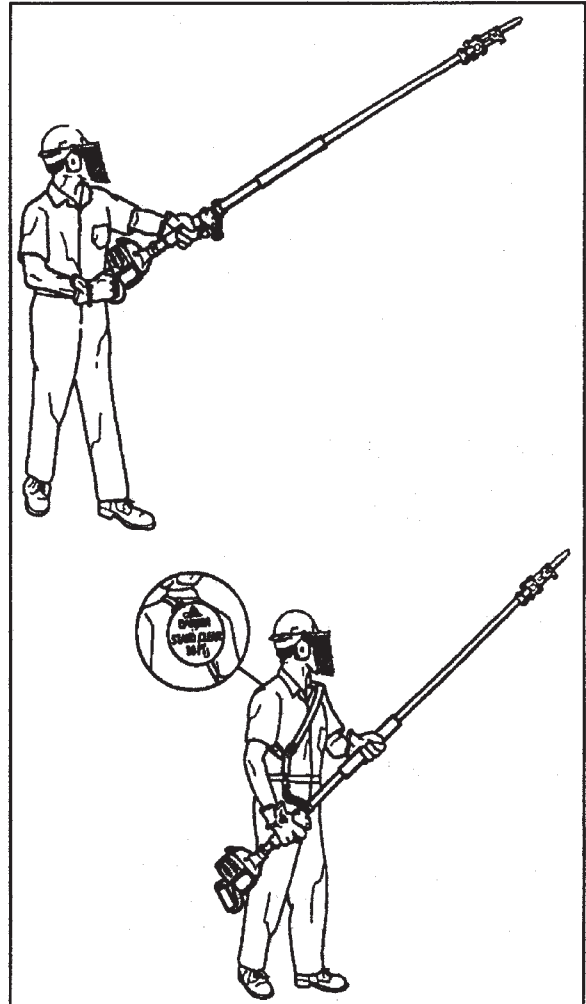

## PROTECTIVE EQUIPMENT

- Always wear eye protection goggles that meet ANSI Z87.1 requirements (Z87 is stamped on the goggles).
- Always wear a **HARD HAT** meeting ANSI Z89.1 requirements.
- The Hard Hat will help protect you from falling branches etc...

continued....

## PROTECTIVE EQUIPMENT

continued...

- Wear hearing protection. If this guideline is not followed, hearing loss can occur. The Occupational Health and Safety Act of 1970 requires the wearing of hearing protection if you use the unit more than two hours per day. Since the guidelines could be revised to require the wearing of hearing protection if you use the unit for less than two hours per day, we recommend that hearing protection be worn at all times.
- Wear snug fitting, durable clothing. Avoid wearing loose clothing that could become entangled when contact is made with the Tree Trimmer.
- Wear shoes with non-skid soles to ensure proper footing.
- Wear non-slip, heavy-duty work gloves to improve your grip on the Tree Trimmer handles. The gloves also help reduce the transmission of machine vibration to your hands.

## PROTECTING OTHERS

Spectators, children, fellow workers and animals must be warned to come no nearer than 33 feet while the Tree Trimmer is in use. People working in the area near the operator should wear the same protective equipment as the operator.

## PHYSICAL CONDITION

Your judgement and/or dexterity may be impaired if you are ill or have taken alcohol or other substances known to affect the way you would normally function. Operate only when in sound mind and body.

## WARNING DANGER PRECAUTION AGAINST VIBRATION AND COLD

It is believed that a condition called Raynaud's Phenomenon which affects fingers of certain individuals is brought about by exposure to cold and vibration. Accordingly, your ECHO Tree Trimmer has vibration dampening devices designed to reduce the intensity of vibration. Exposure to cold and vibration may cause tingling and burning sensations, followed by loss of color and numbness in a person's fingers. We strongly recommend taking the following precautions because the minimum exposure which might trigger the ailment is unknown.

- Keep your body warm - especially head, neck, feet and ankles, and hands and wrist.
- Maintain good blood circulation by performing vigorous arm exercises during frequent work breaks, and also by not smoking.
- Limit the number of hours of operation. Try to fill a part of each work day with jobs where operating the Tree Trimmer or other hand-held power tools is not required.
- If you experience discomfort, redness and swelling of the fingers, followed by whitening and loss of feeling, consult your physician before exposing yourself further to cold and vibration.

## AVOID DAMAGE TO TREE TRIMMER

- If the Tree Trimmer is operated for extended periods in high temperatures, the drive shaft housing and gear case assembly may become very hot (too hot to touch). Allow unit to cool and check lubrication as outlined in service section before continuing.

## USE CORRECT BLADE

### WARNING DANGER

- Serious injury may result from the improper use of blades and the use of improper blades. Read and comply with all safety instructions listed in this manual.
- ECHO, INC. will not be responsible for the failure of cutting devices which have not been tested and approved by ECHO for use with this unit.

## SAFETY PRECAUTIONS WHEN USING BLADES

- Only use ECHO approved blades.
- Do not hit rocks, stones, tree stumps and other foreign objects with the blade.
- Do not use to cut branches larger than 4-1/2" in diameter.
- Do not cut into the ground with the blade.
- If blade end strikes an obstruction, stop engine immediately and inspect blade for damage.
- Do not operate with a dull, bent, fractured or discolored blade.
- Do not run engine at full throttle without a load.
- Remove all foreign objects from work area.
- Refer to page i for safety decals on shaft.
- Keep bystanders a minimum of 33 feet from operator.
- Hold front cutting guide against branch when cutting. This will help prevent whipping of the branch.
- Look out for branch immediately behind the branch being cut. If blade hits rear branch damage to blade will occur.

CORRECT

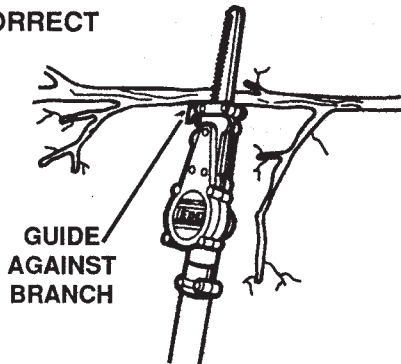

NOT CORRECT

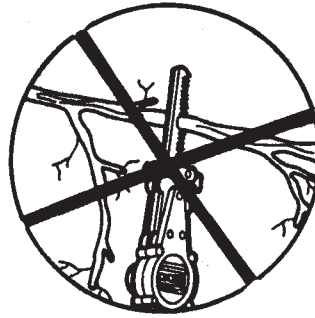

BLADE HITS REAR BRANCH

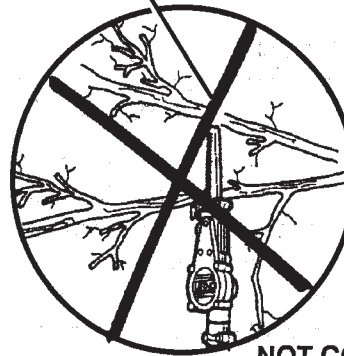

NOT CORRECT

## USING SHOULDER STRAP

1. Place shoulder strap over your head and place on your left shoulder. Adjust straps so the quick-release latch rests just below the waist on your right side.
2. Attach tree trimmer to strap.
3. Adjust strap hook placement on driveshaft housing as necessary for balance and comfort.

### WARNING DANGER

In case of an emergency, pull the quick-release collar to disconnect the tree trimmer from the harness.

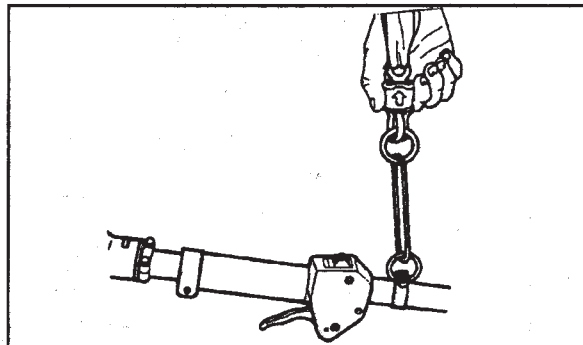

# OPERATION TIPS

The SRS-2100 Tree Trimmer is designed for light to medium trimming of limbs and branches up to 4.5" in diameter. Follow these tips for successful operation.

- Long branches should be removed in several pieces.
- Do not stand directly beneath branch being cut.
- Plan cut carefully. Check direction branch will fall.
- Undercutting should be used to prevent bark tearing.

- When ready to cut,
  - \* hold "front cutting guide" against branch - DO NOT use back and forth sawing action,
  - \* accelerate to full throttle,
  - \* apply cutting pressure,
  - \* ease cutting pressure when nearing end of cut to maintain control,
  - \* use "hook" (bottom of "front cutting guide") to pull cut branches from tree.
- **DO NOT USE FOR FELLING OR BUCKING.**

## FUEL

### HANDLING FUEL

#### **WARNING ▲ DANGER**

Handle fuel carefully. It is extremely flammable. Follow all rules listed below to help prevent fire or explosion which may result in severe injury or death.

- Never smoke or allow flame or sparks near fuel.
- Always fill the fuel tank outdoors. Never pour fuel indoors.
- Never refuel the engine when it is hot or running.
- Always use an approved, safe fuel container.
- After fueling, always wipe up spilled fuel.
- Always move at least 10 feet away from the fueling spot before starting the engine.
- Never store the trimmer with fuel in the tank — a fuel leak could start a fire.

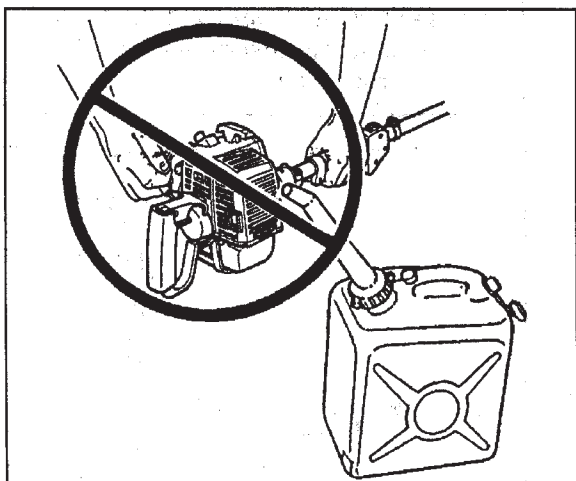

### MIXING FUEL

#### FUEL

The engine uses two-stroke fuel, a mixture of gasoline and specially blended ECHO branded 2-stroke oil. 50:1 preferred, 32:1 alternate choice.

#### GASOLINE

Use branded 89 octane (R+M+2) unleaded gasoline or gasohol (maximum 10% ethyl alcohol, no methyl alcohol).

#### MIXING

Follow directions on oil container.

#### STORING FUEL

Store fuel only in clean, safe, approved container. Check and follow local ordinances on type and location of storage containers.

#### **IMPORTANT**

Two-stroke fuel may separate. Shake fuel container thoroughly before each use.

#### **IMPORTANT**

Stored fuel ages. Do not mix more fuel than you expect to use in a month.

# STARTING AND STOPPING

## SAFE STARTING TECHNIQUES

### NOTE

- Check unit for loose nuts, bolts and screws before starting.
- Always clear work area of debris before starting operation.
- Start unit on the ground with throttle set at idle.
- **DO NOT** start if blade is obstructed by the ground or any other object.
- When pulling starter rope, use short pulls, 1/2 to 2/3 of rope length.
- Do not allow the starter handle to snap back against the housing.
- Always hold the unit firmly.

## STARTING COLD ENGINE

### WARNING ▲ DANGER

When engine starts, the blade may move even with trigger in low-speed position.

### NOTE

See description, page 2, for explanation of how components operate.

1. Slide ignition switch to START/RUN position.
2. Push purge bulb 3 to 4 times (or until constant flow of fuel is visible in fuel return line).
3. Start engine at idle.
4. Close choke and pull starter rope until engine fires.
5. Open choke.
6. Restart engine and allow to warm up.

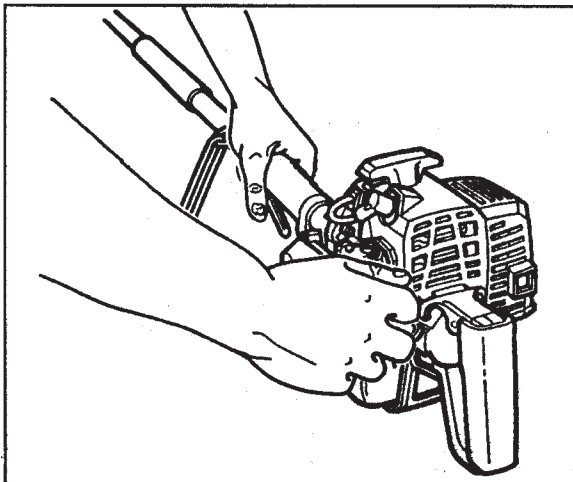

## STARTING WARM ENGINE

1. If fuel tank was emptied during previous operation, refill tank and push purge bulb 3 to 4 times or until constant flow of fuel is visible in fuel return line.
2. Slide ignition switch to START position.
3. Be certain choke is open.
4. Start engine at idle.
5. Pull starter handle.

### NOTE

If engine does not start after 4 pulls, use cold start procedure.

## STOPPING ENGINE

1. Release throttle trigger and allow engine to idle.
2. Slide ignition switch to STOP position.

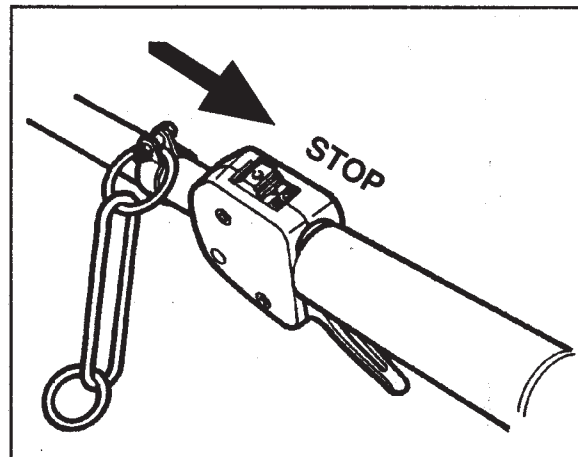

### WARNING ▲ DANGER

If engine does not stop, close choke to stall engine. Have your ECHO dealer inspect and repair ignition switch before using Tree Trimmer again.



# SERVICE MAINTENANCE GUIDE

AREA	MAINTENANCE	PAGE	BEFORE USE	MONTHLY	YEARLY
Air Filter	Clean/Replace	9	●		
Fuel Filter	Inspect/Replace	9		●	
Spark Plug	Inspect/Clean/ Adjust/Replace	9		●	
Carburetor	Adjust	10			●
Cooling System	Inspect/Clean	12	●		
Muffler (Spark Arrestor)	Inspect/Clean	11		●	
Drive Shaft	Grease				
Gear Housing	Grease	12			
Starter Rope	Inspect/Replace			●	
Blade	Inspect/Clean		●		
Fuel Leaks	Inspect/Repair		●		
Screws, Bolts & Nuts	Inspect, Tighten/ Replace		●		
Fuel Line	Inspect			●	

\*  
\*

**IMPORTANT**

Time intervals shown are maximum. Actual use and your experience will determine the frequency of required maintenance.

\* Every 20 - 30 hours.

## TROUBLESHOOTING

Problem		Cause	Remedy	
Engine —starts hard —does not start				
Engine Cranks	Fuel at carburetor	No fuel at carburetor	<ul style="list-style-type: none"> <li>•Fuel strainer clogged</li> <li>•Fuel line clogged</li> <li>•Carburetor</li> </ul>	<ul style="list-style-type: none"> <li>•Clean.</li> <li>•Clean.</li> <li>•See your Echo dealer</li> </ul>
	Fuel at cylinder	No fuel at cylinder	<ul style="list-style-type: none"> <li>•Carburetor</li> </ul>	<ul style="list-style-type: none"> <li>•See your Echo dealer</li> </ul>
		Muffler wet with fuel	<ul style="list-style-type: none"> <li>•Fuel mixture is too rich</li> </ul>	<ul style="list-style-type: none"> <li>•Open choke</li> <li>•Clean/replace air filter</li> <li>•Adjust carburetor</li> <li>•See your Echo dealer</li> </ul>
	Spark at end of plug wire	No spark at end of plug wire	<ul style="list-style-type: none"> <li>•Ignition switch off</li> <li>•Electrical problem</li> </ul>	<ul style="list-style-type: none"> <li>•Turn switch on</li> <li>•See your Echo dealer</li> </ul>
	Spark at plug	No spark at plug	<ul style="list-style-type: none"> <li>•Spark gap incorrect</li> <li>•Covered with carbon</li> <li>•Fouled with fuel</li> <li>•Spark plug defective</li> </ul>	<ul style="list-style-type: none"> <li>•Adjust. 0.6-0.7 mm (0.024-0.028)</li> <li>•Clean or replace.</li> <li>•Clean or replace.</li> <li>•Replace plug</li> </ul>
Engine does not crank		Internal engine problem	<ul style="list-style-type: none"> <li>•Internal engine problem</li> </ul>	<ul style="list-style-type: none"> <li>•See your Echo dealer</li> </ul>
Engine runs	Dies or Accelerates poorly	<ul style="list-style-type: none"> <li>•Air filter dirty</li> <li>•Fuel filter dirty</li> <li>•Fuel vent plugged</li> <li>•Spark plug</li> <li>•Carburetor</li> <li>•Cooling system plugged</li> <li>•Exhaust port/spark arrestor screen plugged</li> </ul>	<ul style="list-style-type: none"> <li>•Clean or replace</li> <li>•Replace</li> <li>•Plugged</li> <li>•Clean and adjust/replace</li> <li>•Adjust</li> <li>•Clean</li> <li>•Clean</li> </ul>	

# SERVICE

## CLEANING AIR FILTER (Before Each Use)

1. Close choke. Loosen screw and remove air filter cover.
2. Remove air filter (element is in the cover).

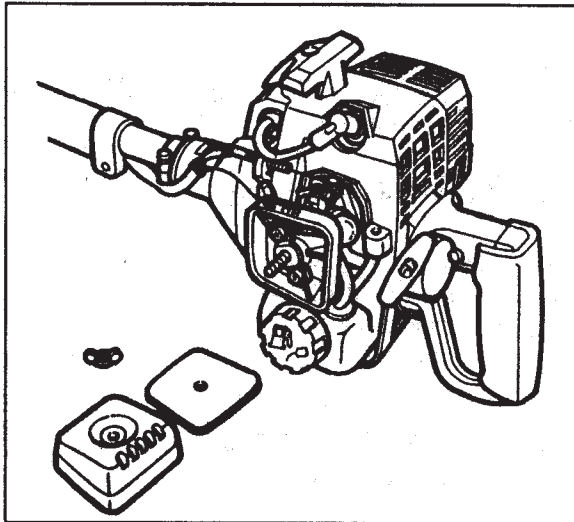

### NOTE

If filter is excessively dirty or no longer fits properly, replace it.

3. Brush dirt from filter or clean with compressed air.
4. Reinstall filter in cover.
5. Reinstall cover and tighten screw.

## FUEL SYSTEM INSPECTION

Poor quality fuel, e.g. high alcohol content, can cause rapid deterioration of plastic and rubber components. Due to unknown fuel quality, it is important that internal and external fuel lines, fuel cap gaskets, carburetor diaphragms and all other plastic and rubber fuel system components be checked a minimum of twice yearly (more often when unit is used commercially). Replace any part that is defective or questionable.

## REPLACING FUEL FILTER (Check Periodically).

1. Use a piece of steel wire to pick up fuel filter through fuel tank opening.
2. Pull old filter from fuel line.
3. Install new filter element.

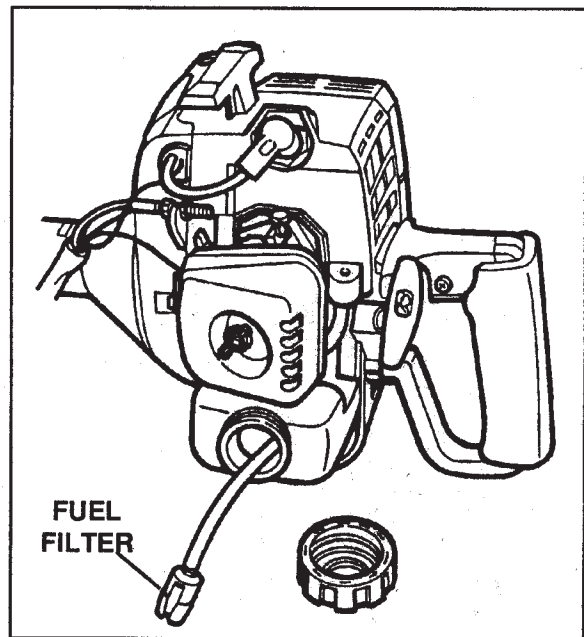

## CHECK SPARK PLUG (Check Periodically)

1. Check plug gap. Correct gap is 0.6 - 0.7 mm (0.024 - 0.028).
2. Inspect electrode for wear.
3. Inspect insulator for oil or other deposits.
4. Replace plug if needed, tighten to 145-155 kg - cm (125 - 135 in. lb.)

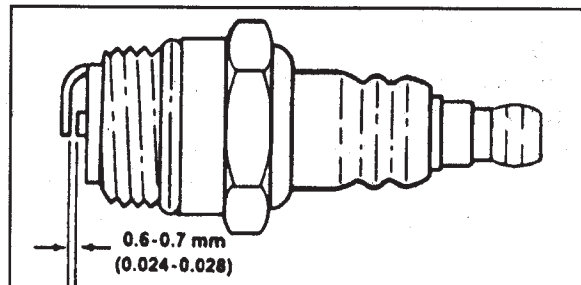

# CARBURETOR ADJUSTMENT (As Needed)

## General

If the carburetor requires adjustment, follow these procedures.

### NOTE

The diaphragm carburetor has three external adjustments. Each adjustment affects the others.

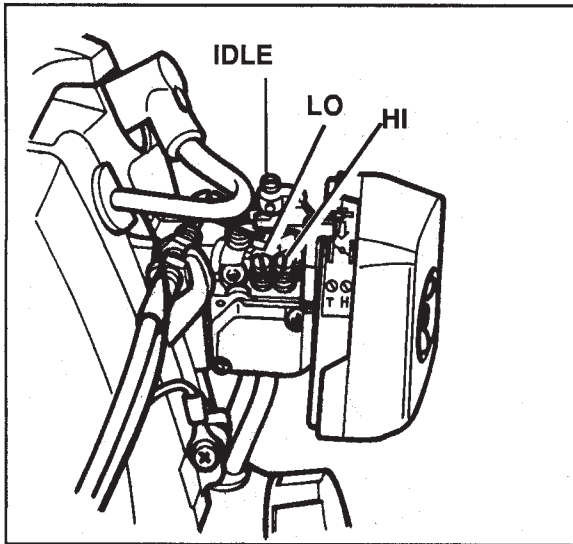

The idle speed adjustment screw controls the throttle opening at idle position.

The low (LO) speed adjustment screw controls the volume of fuel/oil mixture at low engine speed. It also controls the supplementary fuel required to obtain smooth progression from idling to high speed.

The high (HI) speed adjustment screw controls the volume of fuel/oil mixture at full throttle.

## INITIAL ADJUSTMENT

### NOTE

The needle screws have a sharp point. To avoid carburetor damage, do not use excessive force when seating needle in body.

1. Turn HI and LO adjustment screws clockwise until seated lightly in carburetor body.
2. Turn LO adjustment screw counter clockwise one turn.
3. Start engine and allow it to run at high idle until warm (approx. 2-3 minutes).

### NOTE

Idle speed screw may have to be readjusted to keep engine from stalling.

## Idle Speed Adjustment

The idle speed adjustment screw controls the throttle opening at idle position. If the idling adjustment is too low or too high, use the following procedure.

### NOTE

If the following adjustment does not result in satisfactory performance, see your ECHO Dealer.

1. Start engine and allow to warm up (2-3 minutes).
2. Turn idle speed screw clockwise until blade begins to move.
3. Turn idle speed screw counter clockwise until blade stops. Correct idle speed is  $2750 \pm 250$  RPM.

## Low Speed Adjustment

1. Slowly turn the LO adjustment screw clockwise and note the position when engine speed drops.
2. Turn the LO adjustment screw counter clockwise and note position when engine speed drops.
3. Set the screw midway between these points.
4. Turn the idle speed screw clockwise until blade just begins to move.
5. Turn idle speed screw counter clockwise one-half turn to stop blade from turning.

## High Speed Adjustment

### NOTE

Engine must be at normal operating temperature.

1. Turn the HI adjustment screw counter clockwise 1-1/4 turns.

### IMPORTANT

Do not run the engine at full throttle longer than 5-6 seconds without load to avoid damage to engine.

2. While running the engine at full throttle, turn the HI adjustment screw slowly clockwise until the engine runs smoothly.
3. Turn the screw counter clockwise 1/8 turn to obtain optimum fuel mixture for full power under load conditions.

### NOTE

It may be necessary to reset idle speed as outlined in steps 4 and 5 of "Low Speed Adjustment" section.

## CLEANING MUFFLER AND EXHAUST PORT (Check Periodically)

1. Remove spark plug lead from spark plug, and throttle cable from carburetor swivel.
2. Remove screws that secure engine cover.
3. Pull engine cover away from engine.

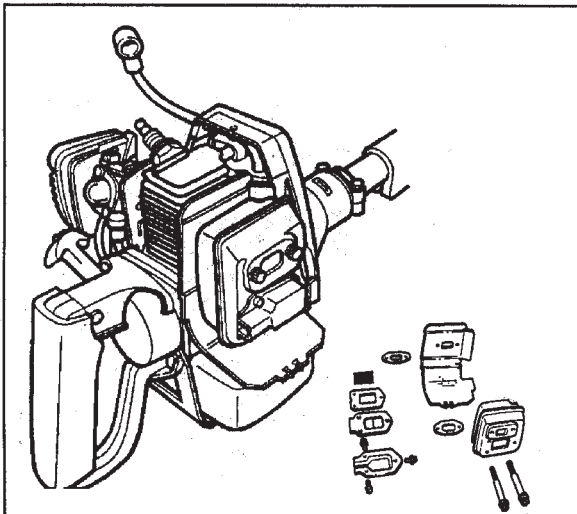

4. Remove muffler lid and spark arrester screen. Replace screen if it is plugged, cracked or has holes burned through it.
5. Remove muffler and heat shield.
6. Pull engine over until piston wall closes exhaust port. Clean deposits from muffler, spark arrester screen and cylinder exhaust port, with a soft metal brush or wood scraper tool.

### NOTE

Be careful not to scratch the cylinder or piston when cleaning the cylinder exhaust port.

7. Inspect gaskets, replace if necessary.
8. Install heat shield and muffler.
9. Install spark arrester.
10. Install engine cover and spark plug lead.

## COOLING SYSTEM MAINTENANCE

### IMPORTANT

To maintain proper engine operating temperatures, cooling air **must** pass freely through the cylinder fin area. This flow of air carries combustion heat away from the engine.

Overheating and engine seizure can occur when:

- Air intakes are blocked, preventing cooling air from reaching the cylinder, or
- Dust and grass build up on the outside of the cylinder. This build-up insulates the engine and prevents the heat from leaving.

Removal of cooling passage blockages or cleaning of cylinder fins is considered "Normal Maintenance". Any resultant failure attributed to lack of maintenance is not warranted.

The cooling system relies on cooling air entering the engine through a grille located between the fuel tank and starter. The cooling fan pushes this air through the cylinder area and out the opening in the engine cover.

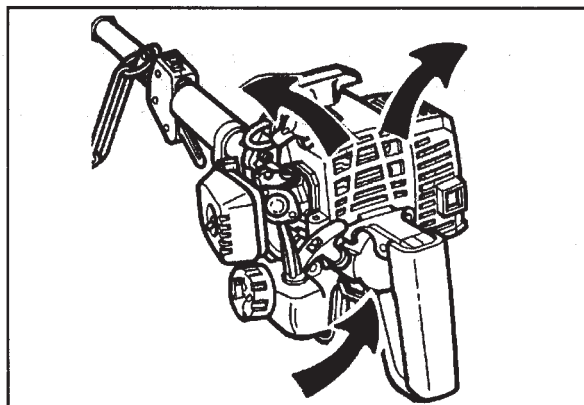

## Cleaning Grille

Remove accumulated debris from intake grille.

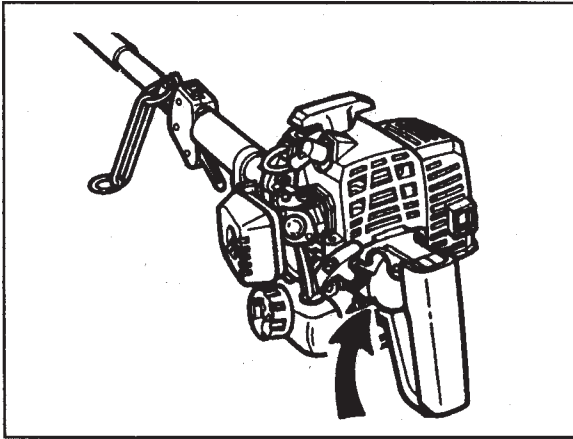

## Cleaning Cylinder Fins (Check Periodically)

1. Remove dust and dirt from between fins.

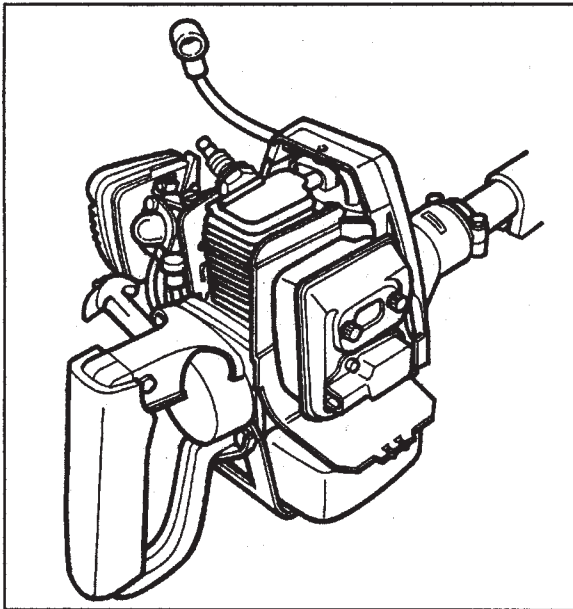

2. If greater access is needed to thoroughly clean fins, remove engine cover as outlined in steps 1, 2 and 3 in "Cleaning Muffler and Exhaust Port".

## BLADE REPLACEMENT INSTRUCTIONS

The blade must be replaced when cracked, bent, broken or when the drive pin hole is worn.

### WARNING DANGER

Never try to replace blade with engine running. This blade is **VERY** sharp, wear heavy gloves to protect your hands when handling it.

Parts may fly out during blade removal. Wear eye protection meeting ANSI Specification Z87.1.

## BLADE REMOVAL

- Remove the six socket head screws. Remove cover and top blade guide from gear box.
- Move the connecting rod and blade to their most forward travel position. Place a flat blade screwdriver between blade and connecting rod. Twist screwdriver to separate pin from blade and pull blade out. Remove bottom blade guide.
- Remove dirt and contaminated grease. Clean the blade roller guides and upper and lower blade guides and coat with fresh EP2 lithium base grease.

## IMPORTANT

If blade was broken, make certain all pieces are removed before new blade is installed.

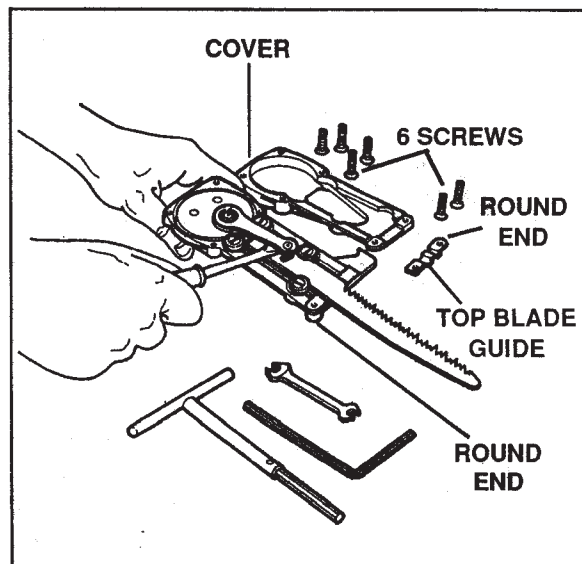

## BLADE INSTALLATION

- Align new blade in grooves of roller guides and push in. Again place connecting rod in its most forward travel position. Move blade in or out to align hole in blade with pin on rod and install pin in blade hole by lifting the connecting rod with a screwdriver.

### IMPORTANT

Make sure the blade teeth are facing downward towards the hook portion of the gear housing.

- Install the upper and lower blade guide plates. The rounded ends of both blade guide plates must align with the round corner of the housing.
- Install gearcase cover. Install the two short socket head capscrews in the front, the remaining 4 screws in the rear.

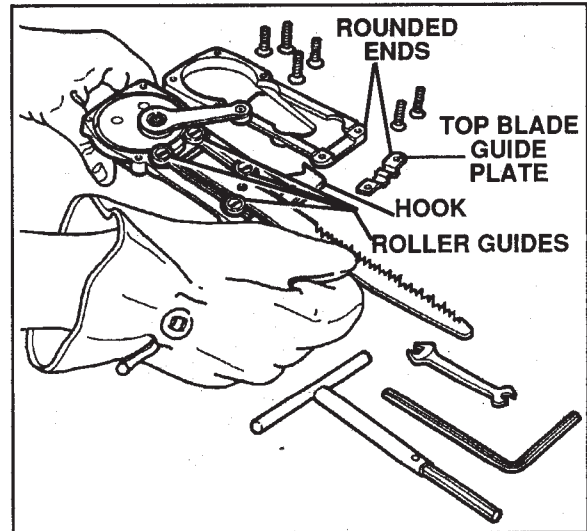

## LUBRICATION

### DRIVE SHAFT

- Loosen two gear box mounting screws and remove location screw - slide gear box from end of housing.
- Wrap shop cloth around end of housing and pull flex cable through it cleaning old grease from cable.
- Inspect cable for damage and wear.
- Coat flex cable with clean EP2 lithium base grease and push back in housing.
- Install gear box (see page 14 for installation).

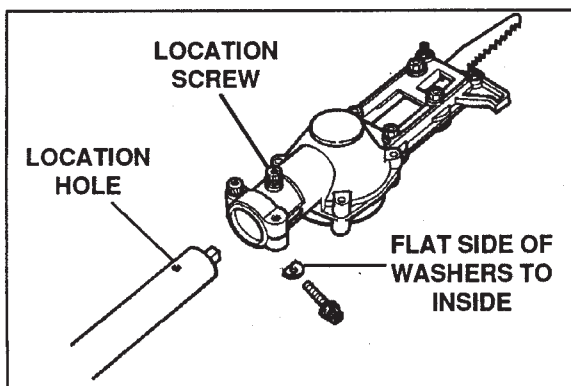

### GEAR HOUSING

#### NOTE

Follow instructions for, "Blade Replacement" for disassembly and reassembly.

- Once disassembled and blade removed, remove dirt and contaminated grease from blade area.
- Hold grease gun against hole in gear shield and pump grease in gear case until fresh grease begins to escape around shield. Remove excess grease.
- Coat Blade and roller guides with fresh grease and reassemble.

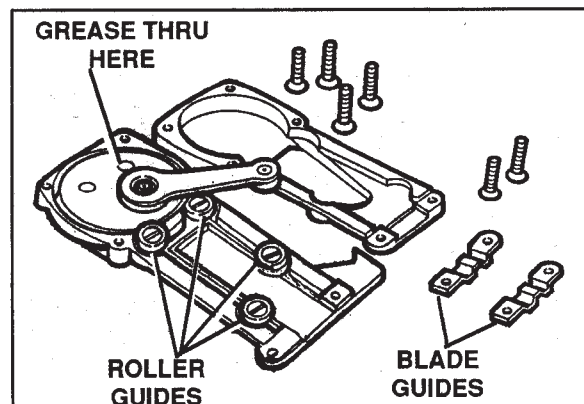

# ASSEMBLY

## INSTALLING DRIVE SHAFT

1. Stand engine upright on a level surface.
2. Loosen the two bolts at drive shaft end

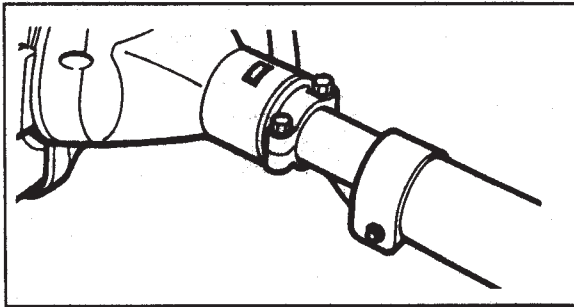

### NOTE

The line on the drive shaft housing must be in contact with the engine (arrow on drive shaft indicates line).

4. Rotate the drive shaft housing until bearing housing is in line with the engine.
5. Tighten bolts.

## INSTALLING GEAR BOX

1. Loosen three screws (screw and washer shown removed for clarity) and slide gear box on drive housing. Location screw must not be inside housing during assembly.

### IMPORTANT

Flat side of washers must be against drive housing.

2. Rotate gear housing to engage drive cable in gear.

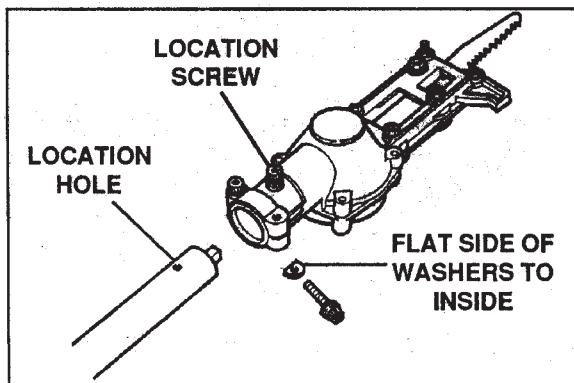

## ASSEMBLING THROTTLE CABLE

### NOTE

The engine is delivered with throttle cable (engine side) separated.

1. Remove air filter cover. Loosen nut (A).
2. Insert throttle cable in slot.
3. Finger tighten nut (A).
4. Attach inner cable to the swivel (B).

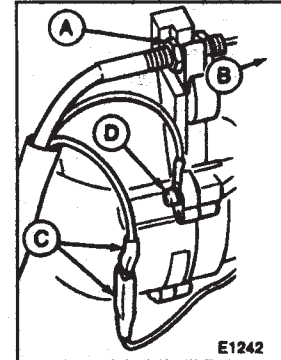

### NOTE

It is important that the nipple of the throttle cable fit into the slot of the swivel.

5. Tighten nut (A).
6. Check throttle for freedom of movement and make sure it returns to idle position.
7. Connect stop lead to stop lead connector (C).
8. Secure ground lead under screw (D) on housing.
9. Reinstall air filter cover.

# STORAGE

## LONG TERM STORAGE (Over 60 Days)

Do not store your unit for a prolonged period of time (60 days or longer) without performing protective storage maintenance which includes the following:

1. Store unit in a dry, dust free place, out of the reach of children.

### WARNING DANGER

Do not store in enclosure where fuel fumes may accumulate or reach an open flame or spark.

2. Place the ignition in the "OFF" position.
3. Remove accumulation of grease, oil, dirt and debris from exterior of unit.
4. Perform all periodic lubrication and services that are required.
5. Tighten all the screws and nuts.
6. Drain the fuel tank completely and pull the starter handle several times to remove fuel from the carburetor.

7. Remove the spark plug and pour 1/4 oz. (1/2 tablespoon) of fresh, clean, 2-stroke engine oil into the cylinder through the spark plug hole.

- A. Place a clean cloth over the spark plug hole.
- B. Pull the recoil starter handle 2-3 times to distribute the oil inside the engine.

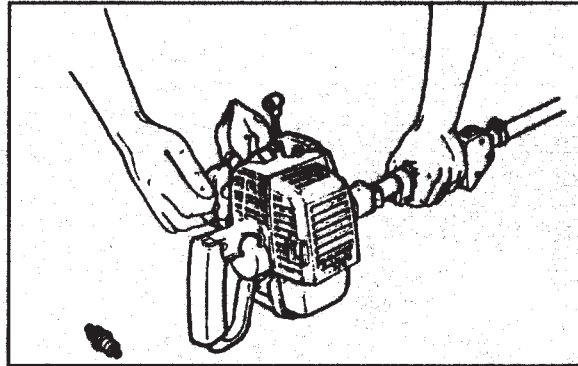

- C. Observe the piston location through the spark plug hole. Pull the recoil handle slowly until the piston reaches the top of its travel and leave it there.
8. Install the spark plug (do not connect ignition cable).

## SPECIFICATIONS

Length	2345mm (92.3 in.)
Width	220mm (8.7 in.)
Height	220mm (8.7 in.)
Weight (dry weight with cutter)	11.3
Type of Engine	Air-cooled, two-stroke, single cylinder gasoline engine
Bore	32.2 mm (1.268 in.)
Stroke	26.0 mm (1.04 in.)
Displacement	21.2 cc (1.29 cu. in.)
Exhaust System	Spark arrester muffler
Carburetor	Zama diaphragm model C1U with purge
Ignition System	Flywheel magneto, capacitor discharge ignition type
Spark Plug	NGK BPM-7Y, Champion CJ-7Y
Fuel	Mixed fuel
Fuel Oil Ratio	50:1 ratio with ECHO oil or 32:1 ratio special oil approved by ECHO
Gasoline	89 Octane (Unleaded)
Oil	Designated, two-stroke, air cooled engine oil
Fuel Tank Capacity	0.4 lit. (14.2 US fl. oz.)
Starter System	Automatic rewind starter
Clutch	Centrifugal type
Vibration Dampening System	Rubber cushion for engine and foam covered handle
Drive Shaft	1/4 in. flexible shaft
Gear Case	1: 2.33



## SERVICING INFORMATION

### PARTS

Genuine ECHO Parts and ECHO Re Power Parts and Assemblies for your ECHO products are available only from an Authorized ECHO Dealer. When you do need to buy parts **always** have the Model Number, Type number and Serial Number of the unit with you. You can find all three numbers on the engine housing. For future reference, write them in the space provided below.

Model No. \_\_\_\_\_ SN. \_\_\_\_\_

### SERVICE

Service of this product during the warranty period must be performed by an Authorized ECHO Service Dealer. For the name and address of the Authorized ECHO Service Dealer nearest you, ask your retailer or call: 1-800-432-ECHO. When presenting your unit for Warranty service/repairs, proof of purchase is required.

### ECHO CONSUMER PRODUCT SUPPORT

If you require assistance or have questions concerning the application, operation or maintenance of this product, you may call the ECHO Consumer Product Support Department at 1-800-673-1558 from 8:30 am to 4:30 pm (Central Standard Time) Monday through Friday. Before calling, please know the model and serial number of your unit to help your Consumer Product Support Representative.

### WARRANTY REGISTRATION

You may register your Echo equipment using the warranty registration card or register on-line at [www.echo-usa.com](http://www.echo-usa.com). Registering provides a direct link between you and ECHO if we find it necessary to contact you.

### ADDITIONAL OR REPLACEMENT MANUALS

**Safety Manuals** in English/Spanish or English/French are available, free of charge, from your ECHO dealer or at [www.echo-usa.com](http://www.echo-usa.com).

**Operator's and Parts Manuals** are available by:

- Downloading free from [www.echo-usa.com](http://www.echo-usa.com)
- Purchasing from your Echo Dealer.
- Sending a check or money order for \$2.00 per Parts Catalog or \$1.50 per Operator's Manual made payable to ECHO, INCORPORATED. State on a sheet of paper the model number and serial number of the ECHO unit you have, part number of the manual (if known), your name and address, and mail to address below.

**Safety Videos** are available from your Echo dealer. A \$5.00 shipping charge is required for each video.

### Available Parts Catalog Parts Lists

SRS-2100 S/N 001001 & Up      Part Number 99922202342

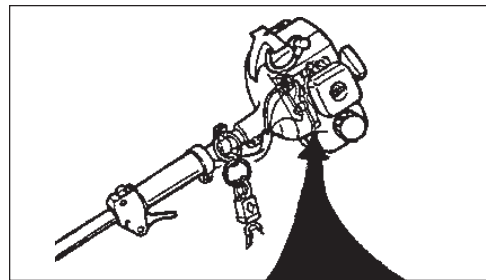

**DEALER?  
CALL  
1-800-432-ECHO  
OR  
[www.echo-usa.com](http://www.echo-usa.com)**

**CONSUMER PRODUCT  
SUPPORT  
1-800-673-1558  
8:30 - 4:30 MON - FRI C.S.T.**



**ECHO**  
ECHO, INCORPORATED  
400 OAKWOOD ROAD  
LAKE ZURICH, IL 60047  
[www.echo-usa.com](http://www.echo-usa.com)